

Differential thermal analysis of mechanically activated sphalerite

P. Baláž^a, H.-J. Huhn^b and H. Heegn^c

^a *Mining Institute of Slovak Academy of Sciences, 043 53 Košice (Czechoslovakia)*

^b *Eckart-Werke, Werk Günterstal, W-8564 Velden (Germany)*

^c *Forschungsinstitut für Aufbereitung, O-9200 Freiberg (Germany)*

(Received 12 April 1991)

Abstract

The influence of the mechanical activation of sphalerite on the limiting temperatures of DTA exoeffects was investigated. The structural sensitivity of decomposition was ascertained and an empirical relation was derived relating the values of specific surface area and the content of crystalline phase *X* of mechanically activated samples with the values of limiting temperatures of individual DTA exoeffects.

INTRODUCTION

Sphalerite is a frequently studied mineral. The interest in this sulphide derives from the metallurgical industry in which it is exploited as the main zinc-containing mineral, with accessory metals, especially cadmium and manganese. Non-traditional applications of sphalerite include the exploitation of its luminescence properties and memory effect in electronics [1,2].

The thermal analysis of sphalerite has been predominantly applied to studying the influence of the amount and granularity of the sample, the atmosphere, type of inert, heating rate and other quantities on the parameters of the DTA effects [3–6]. Kopp and Kerr investigated the effect of substituting isomorphous iron for zinc in the sphalerite lattice on the course of the DTA effects [7]. A linear increase in the lattice constant of sphalerite and, thus, a disordering of its crystal structure occurs when the iron content increases (0.1–13%). At the same time, the temperature of the DTA effects decreases.

The aim of this study has been to determine which changes in the DTA effects of sphalerite appear after its mechanical activation which is commonly applied as a process producing disordering in sulphidic minerals [8,9].

EXPERIMENTAL

The investigations were carried out with sphalerite originating from the Soviet Union of composition 42.53% Zn, 11.28% Fe, 39.77% S, 2.40% SiO₂ and 4.02% insoluble residue.

The mechanical activation of samples was performed in a planetary mill (Pulverisette 4, Fritsch, Germany) under the following conditions: ball charge, 25 balls of ϕ 15 mm and 5 balls of ϕ 25 mm; ball material, tungsten carbide; weighed amount of sample 10 g; time of grinding, t_G , 5–60 minutes in methanol (100 ml); relative acceleration of the mill, b/g , 10.3, initial particle size of sphalerite, 1000–40 μm .

The specific surface area, S_A , was determined from the adsorption isotherms of benzene vapour using the BET method [10].

The change in content of the crystalline phase X was estimated by the diffraction phase analysis according to ref. 11 using the equation

$$X = \frac{U_0 I_X}{I_0 U_X} \quad (1)$$

where U_0 and U_X are the backgrounds of non-activated (reference) and mechanically activated samples, respectively, and I_0 and I_X are the intensities of the (311) X-ray diffraction peak of sphalerite for non-activated and mechanically activated samples, respectively.

The diffraction data were obtained on a DRON 2.0 (USSR) diffractometer using the following regime: Cu K α radiation, 30 kV, 20 mA; time constant, 1 s; limit of measurement, 10 impulses s⁻¹; rate of detector, 2° min⁻¹; paper speed, 2.4 m h⁻¹.

Combined TG–DTG–DTA measurements were carried out on a thermoanalyser TA (Mettler, Switzerland) working in the following mode of operation: sample weight, 8 mg; reference material, 8 mg of Al₂O₃; sensitivity: TG, 10 mg; DTG, 5 mg min⁻¹; DTA, 100 μV ; temperature range, 25–1000 °C; air flow-rate 5 l h⁻¹; linear rate of heating, 6 °C min⁻¹; thermocouple, Pt–Pt/Rh.

DTA of oxidative decomposition of mechanically activated sphalerite

The oxidation of sphalerite was investigated by differential thermal analysis. The DTA curves are shown in Fig. 1. The oxidative decomposition of sphalerite proceeds in three typical stages. The first and second stages ($T = 400\text{--}750$ °C) are characterised by exothermic processes and by the fact that the exoeffects depend on the time of mechanical activation and are shifted to lower values. The third stage ($T > 800$ °C) is endothermic and does not exhibit any dependence on the time of mechanical activation. The results are consistent with literary data [12]. The exothermic reaction



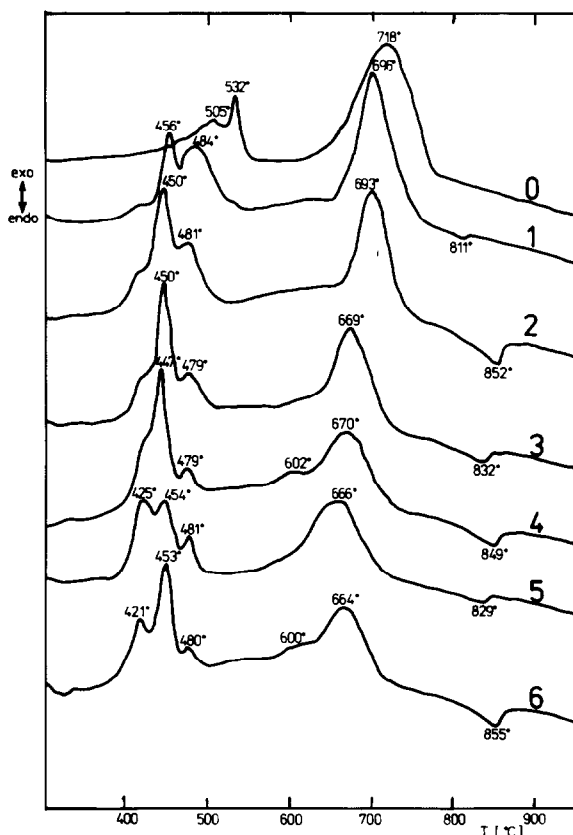

Fig. 1. DTA curves of sphalerite; time of mechanical activation: 0, 0 min; 1, 5 min; 2, 10 min; 3, 20 min; 4, 30 min; 5, 45 min; 6, 60 min.

takes place in the region 350–800 °C. This reaction is accompanied by exothermic formation of sulphate which is dependent on the presence of SO_2



At temperatures above 800 °C, the solid products of reactions (2) and (3) may enter into exothermic reaction to give the oxysulphate $\text{ZnO} \cdot \text{ZnSO}_4$ [13].

Owing to the presence of Fe and SiO_2 in the original sample [13], the formation of zinc ferrite, zinc silicate or magnetite cannot be ruled out.

Influence of surface structural changes in mechanically activated sphalerite on the temperature of the DTA effect

The changes in specific surface, S_A , and the content of the crystalline phase, X , are plotted as a function of the time of planetary grinding, t_G , in

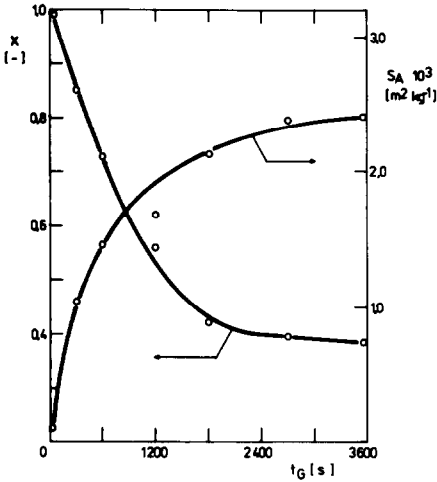

Fig. 2. Variation of specific surface S_A and content of crystalline phase X with time of mechanical activation t_G .

Fig. 2, which indicates that the mechanical activation has a positive influence on the formation of new surface and the disordering of the mineral structure, especially for grinding times up to 1800 s. The retardation of the kinetics of these processes at $t_G > 1800$ s may be a consequence of the formation of agglomerates, the occurrence of which in the course of dry grinding was described in our preceding publication [14].

The limiting temperatures T_{DTA} of individual exoeffects in the course of the oxidation of sphalerite are plotted as a function of time in Fig. 3. In comparison with a non-activated sample, the values of T_{DTA} decrease with

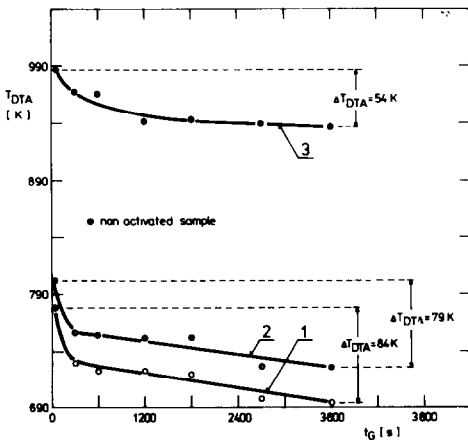

Fig. 3. Variation of limiting temperatures T_{DTA} of individual exoeffects of sphalerite with time of mechanical activation t_G : 1, exoeffect I (778–694 K); 2, exoeffect II (805–726 K); 3, exoeffect III (991–937 K).

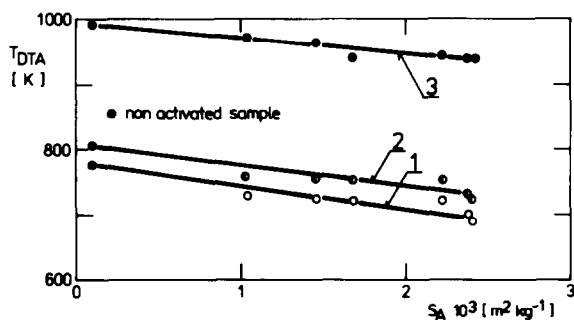

Fig. 4. Dependence of limiting temperatures T_{DTA} of individual exoeffects of sphalerite on specific surface S_A : 1, exoeffect I (778–694 K); 2, exoeffect II (805–726 K); 3, exoeffect III (991–937 K).

increasing values of t_G . This decrease is most significant for the exoeffect at the lowest temperature (778–694 K).

The difference between the values of the limiting temperatures, ΔT_{DTA} , expressed by the relation

$$\Delta T_{DTA} = T_{DTA}^* - T_{DTA}^0 \quad (4)$$

where * denotes the mechanically activated sample and 0 the non-activated sample, is equal to 84 K for exoeffect I. For exoeffects II and III appearing at higher temperatures, the values of ΔT_{DTA} are lower (79 and 54 K, respectively).

The proportion of different oxidation products formed, including oxides, sulphates, oxysulphates and others, increases with temperature. These products change significantly the quality of the surface and a high-temperature sintering of the sphalerite may also occur. Because of structural changes, the probability of annealing the defects formed in sphalerite by mechanical activation increases in the course of application of high temperatures.

The values of T_{DTA} for both quantities (surface area and structural ordering) are plotted in Figs. 4 and 5. The decrease in T_{DTA} values with increasing surface area and decreasing degree of structure ordering ($X < 1$) observed for all exoeffects shows that the exothermic decomposition of sphalerite in an oxidising environment is sensitive to both these quantities.

If we want to determine which of the quantities, specific surface S_A or content of crystalline phase X , is more responsible for the enhanced reactivity of a solid-phase reaction, we must divide the reaction rate by the specific surface area of the reacting samples [15,16].

Figure 6 shows the variation of T_{DTA}/S_A with the content of crystalline phase X of mechanically activated sphalerite plotted for individual exoeffects. The relationship between T_{DTA}/S_A and X can be expressed by the

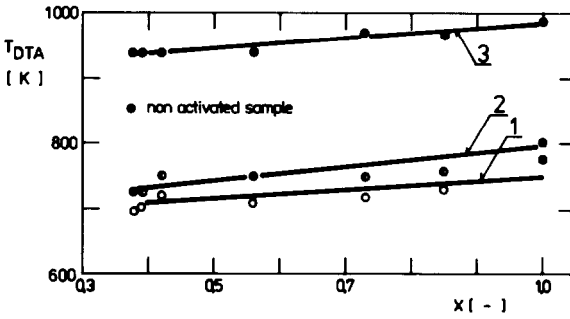

Fig. 5. Dependence of limiting temperatures T_{DTA} of individual exoeffects of sphalerite on content of crystalline phase X : 1, exoeffect I (778–694 K); 2, exoeffect II (805–726 K); 3, exoeffect III (991–937 K).

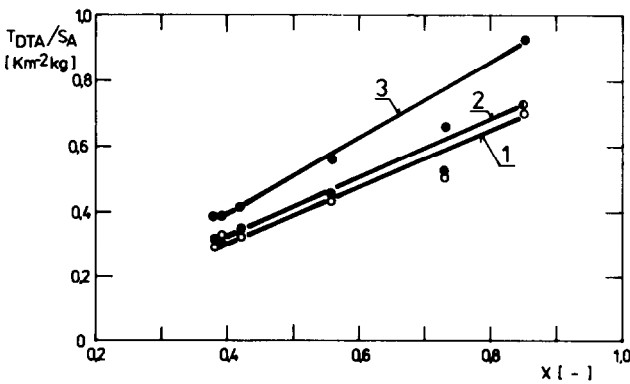

Fig. 6. Dependence of T_{DTA}/S_A on content of crystalline phase X for individual exoeffects of sphalerite: 1, exoeffect I (778–694 K); 2, exoeffect II (805–720 K); 3, exoeffect III (991–937 K).

TABLE 1

Values of parameters a and b and correlation coefficients r of linear regression $T_{DTA}/S_A = a + bX$ for exoeffects I, II and III

Exoeffects	Parameters		Correlation coefficient r
	a	b	
I (778–694 K)	–0.02	0.79	0.974
II (805–726 K)	–0.01	0.82	0.975
III (991–937 K)	–0.02	1.05	0.975

following equation

$$\frac{T_{\text{DTA}}}{S_{\text{A}}} = a + bX \quad (5)$$

for which the values of the parameters a and b , as well as the corresponding correlation coefficients of linear regression r , are given in Table 1. The relations presented show the sensitivity of the thermal oxidation decomposition of sphalerite to structural disordering produced by mechanical activation. The increase in the values of parameter b for exoeffects I–III indicates the influence of the annealing of the structural disorder of sphalerite at increasing temperatures.

REFERENCES

- 1 L. Sodomka, *Mechanoluminescence a její použití*, Academia, Praha, 1985.
- 2 J.M. Hurd and C.N. King, *J. Electron. Mater.*, 8 (1979) 879.
- 3 G.S. Frenc, *Okislenije sulfidov metallov*, Nauka, Moskva, 1964.
- 4 N.D. Topor, *Differencial'no-termičeskij i termovesovoj analiz mineralov*, Nedra, Moskva, 1964.
- 5 R.C. MacKenzie (Ed.), *Differential Thermal Analysis*, Academic Press, London, 1970 (Vol. 1), 1972 (Vol. 2).
- 6 W. Smykatz-Kloss, *J. Therm. Anal.*, 23 (1982) 15.
- 7 O.C. Kopp and P.F. Kerr, *Am. Mineral.*, 43 (1958) 732.
- 8 E.G. Avvakumov, *Mechaničeskije metody aktivacii chimičeskich processov*, Nauka, Novosibirsk, 1986.
- 9 V.G. Kulebakin, *Primenenije mekhanochimii v gidrometallurgičeskich processach*, Nauka-Sibirskoje otdelenije, Novosibirsk, 1988.
- 10 S. Brunauer, P.H. Emmet and E. Teller, *J. Am. Chem. Soc.*, 60 (1939) 309.
- 11 S.M. Ohlberg, D.W. Strickler, *J. Am. Ceram. Soc.*, 45 (1962) 170.
- 12 T.R. Ingraham and H.H. Kellog, *Trans. AIME*, 227 (1963) 1419.
- 13 E.M. Kurian and R.V. Tamhankar, *Trans. Indian Inst. Metallurg.*, 12 (1970) 59.
- 14 P. Baláž and I. Ebert, *Thermochim. Acta*, 180 (1991) 117.
- 15 M. Senna, *Part. Part. Syst. Charact.*, 6 (1989) 163.
- 16 N.Z. Lyakhov, *Mechanical Activation and Reactivity of Solids*, in G. Jimbo, M. Senna and Y. Kuwahara (Eds.), *Proc. 2nd Japan–Soviet Seminar on Mechanochemistry*, Soc. Powder Techn., Japan, 1988, pp. 59–68.